

HAZOP Participants



HAZOP studies are the process industry's accepted standard for critically examining planned or existing processes and procedures and identifying associated hazards to people, the environment or the equipment. The aim of this course is to prepare participants for HAZOP reviews and make them more effective and efficient review team members.

Overview

A hazard and operability study (HAZOP) is a structured and systematic examination of a planned or existing process or operation in order to identify and evaluate problems that may represent risks to personnel or equipment, or prevent efficient operation. A HAZOP review also generates an in depth understanding of the process for all participants, leading to a more robust and reliable plant.

A HAZOP review team usually consists of 6 – 10 persons. Depending on the scope and size of the review, it can take anything from 1 day to several weeks. Having a review team which is familiar with the processes of the review not only significantly improves the quality of the outcome but will also shorten the duration of the review.

This course is aimed at operators, engineers, designers and maintenance personnel who will at some point be part of a HAZOP review team. The objectives of this course are to convey the benefits of HAZOP and the role of the HAZOP review in the process safety framework. It will familiarise the participants with the structure and methods of the review, enabling them to be more effective and efficient review team members. The course will also increase the participants' ability to identify and assess process hazards outside of a review.

The course includes a test which is required for the completion of Unit Standards 19341 and 27243.

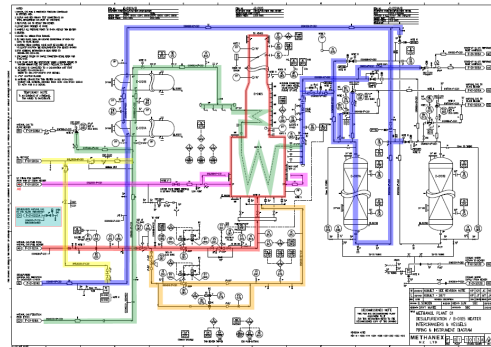

Course Content (1 day)

- The Basic Principles of HAZOP
- Hazard & Risk
- How HAZOP fits into the Hazard Management scheme and the design life cycle.
- The HAZOP Process and team composition
- The review objective & how it affects the review focus.
- Guidewords and their use
- Required documentation & review preparation
- What are the participant's roles and responsibilities?
- Case studies. What level of review is required when?

Maximum number of attendees: 20



Safety Solutions Ltd are New Zealand's leading Process Safety consultants and trainers.

As part of our consultancy portfolio, Safety Solutions Ltd can facilitate HAZOP and other types of hazard identification and risk assessment reviews. We also offer to mentor your team in review facilitation.

Our training courses are also offered as in-house courses with industry specific examples and workshops. For more information about any of our courses please contact Safety Solutions:

E: training@safetysolutions.co.nz

W: www.safetysolutions.co.nz

Other courses by Safety Solutions

- Introduction to Process Safety for Management (1 day)
- Introduction to Process Safety for Operators & Engineers (1 day)
- Hazardous Area Classification (2 days)
- HAZOP Leader (2 days)
- Advanced HAZOP (1 day)
- SIL Facilitators (2 days)
- Risk Assessment (2 days)

Delivered by Safety Solutions for IChemE

- Fundamentals of Process Safety (5 days)
- Layer of Protection Analysis (2 days)